

Distributed by:



www.cascadegeos.com
971-339-1020

FLOATING TURBIDITY BARRIERS consist of a top flotation boom, an impervious fabric curtain extending downward under water, and a heavy galvanized steel chain sealed into a hem along the entire bottom of the curtain to provide ballast to keep the curtain vertical in the water. End hems are sealed around a rope and grommets to allow attachment to each other with rope or bolt/nuts/washers. Color is Tough Guy Yellow.



There are three TYPES of FLOATING TURBIDITY BARRIERS:

Type 1.DOT

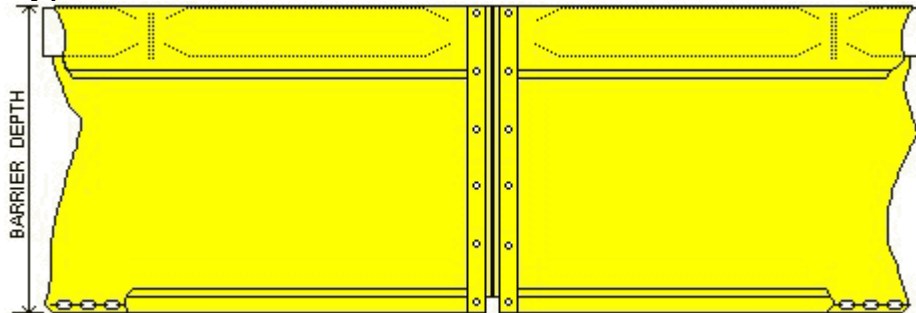

Type 1.DOT is the most frequently specified barrier in the TOUGH GUY® line. It is recommended for construction sites located in protected areas that are exposed only to light winds and to current velocities of less than one foot per second. This type of site may include ponds, shallow lakes, small streams and marshes.

Anchorage consisting of stakes or concrete blocks may be required to maintain the barrier in its required position. Barrier sections are connected by rope lacing or nylon ties which must be furnished by others.

Type 2.DOT

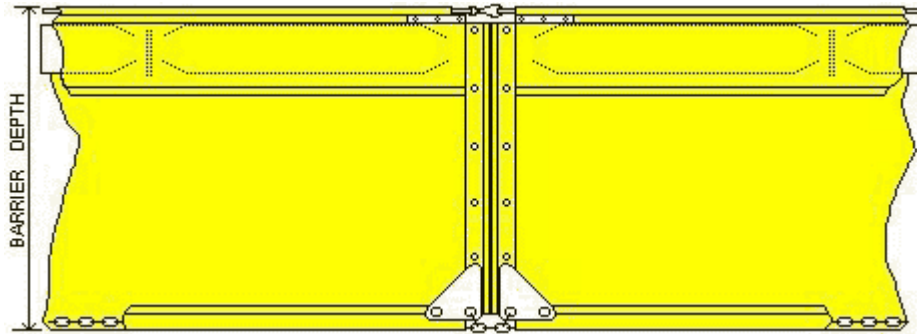

Type 2.DOT is the work horse of the TOUGH GUY® line. It has a top load cable and special stress plates for reinforcing the corners and is designed to handle more severe conditions. It is recommended for lakes, streams, intercoastal and tidal areas where current velocities up to five feet per second are expected.

The anchorage and installation must be designed to meet the site conditions. Contact Aer-Flo Canvas Products, Inc. or a qualified engineer for assistance when extraordinary site conditions are encountered. Barrier sections are connected by rope lacing or nylon ties which must be furnished by others.

Type 3.DOT

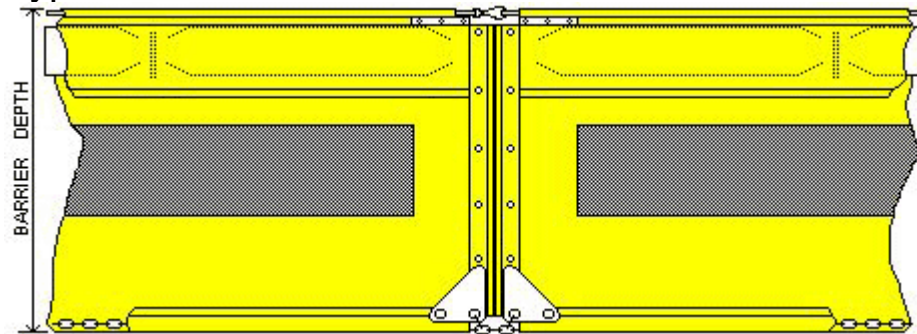

Type 3.DOT is a special adaption of the Type 2 barrier. Approximately 20 % of the area of the barrier skirt fabric is replaced with a polypropylene filter fabric conforming to some State DOT specifications. The filter fabric is inserted to reduce the pressure on the curtain while retaining silt. In actual practice, a filter fabric which is woven tightly enough to retain silt will not significantly reduce pressure on the curtain. Conversely, if the filter fabric is woven loose enough to reduce the pressure on the curtain, it will not be able to retain most silt and sediment particles. In addition, the filter fabric cannot be heatsealed, and must be sewn into the curtain, resulting in a reduction in curtain strength and longevity.

Types 1.DOT, 2.DOT, and 3.DOT MEET OR EXCEED ALL KNOWN FEDERAL AND STATE GOVERNMENTAL SPECIFICATIONS, INCLUDING NPDES PHASE II REQUIREMENTS.

FLOATING BARRIER SIZES: Standard length: 50'. Std. Depths: 3', 5', 10'. Standard sizes are normally in stock ready for immediate shipment. Custom lengths (up to 100') and depths (from 2' to 100') are readily available for rapid manufacture and shipment. Custom colors and accessories, such as **LIGHTED NAVIGATION BUOYS** and **ANCHOR KITS**, are available.

Type 1.m, Type 2.m, & Type3.m are economy versions of .DOT barriers, utilizing lighter components in their construction. Type .m barriers may meet specifications in certain states. Check local requirements.

Basics

Designing Effective Barrier Installations

Floating turbidity barriers are effective in preventing silt and sediment migration into water courses. However certain rules must be followed in order to make the installation successful. Three of the most critical rules are:

1. The silt and sediment must be contained in the retention area long enough to allow it to settle.
2. The preceding rule implies that the silt and sediment particle sizes will actually settle in the time allotted by the construction conditions. The table below shows the time required for particles of various sizes to settle one foot in calm water at 68 degrees F.
3. The current in the containment area must not be so great that the particles are allowed to migrate beyond the barrier before settlement can occur.

If the above conditions are met and the barrier is maintained in its proper position, it will function as intended. Maintaining the barrier in position will involve anchorage. The figure below shows a typical cross-section through a construction site where the disturbed area is likely to cause silt and sediment migration into the waterway. To determine the best distance to place the barrier from the work site, do the following:

1. Select the sediment particle size or description that is relevant to the site.
2. Enter values for the flow velocity and the barrier depth.
3. Click the Length button and the optimum position of the barrier will be displayed.
4. This data must be regarded as only a guide since precise measurements cannot be derived from the general information on which the result is based.

Note that the flow rate has a significant effect on size of the settlement area.

Particle Size (mm)	Description	Time to Settle 1 Ft.
.002	Coarse Clay	24 hours
.006	Fine Silt	3 hours
.02	Medium Silt	14 minutes
.06	Coarse Silt	2 minutes
.2	Fine Sand	8 seconds
.6	Medium Sand	1 second*

*medium sand is not covered by Stokes Law – value is assumed

Specifications

TOUGH GUY® Floating and Staked Turbidity Barrier Specifications							MATERIAL DESCRIPTION
1.DOT	1.m	2.DOT	2.m	3.DOT	3.m	STAKED	
							14 oz. vinyl-polyester fabric
							18 oz. vinyl-polyester fabric (note 4)
							22 oz. vinyl polyester fabric (see Selection)
							Guide below
							Polypropylene woven filter fabric (note 6)
							Heat sealed seams (note 1)
							5/8 inch polypropylene twisted rope edge reinforcement
			Up to 10'				4" x 4" x 48" EPS foam blocks providing 6.67 lbs. / ft. buoyancy in fresh water and 7 / ft. buoyancy in salt water (note 5)
			Over 10'				6" x 6" x 48" EPS foam blocks providing 13.5 lbs. / ft. buoyancy in fresh water and 14.4 / ft. buoyancy in salt water (note 5)
							8" x 8" x 48" EPS foam blocks providing 26.7 lbs. / ft. buoyancy in fresh water and 28.4 / ft. buoyancy in salt water (note 5)
						See Detail	Standard depth = 5 feet (note 2) (Staked=44-1/2")
							Standard length = 50 feet (note 3)
							#4 brass grommets approximately 12" o.c. in edges for laced connection
							#5 brass grommets approximately 12" o.c. in edges for laced connection
							Aluminum stress plates at top and bottom corners
							3/16 inch galvanized steel ballast chain - .39 lbs / 100 ft.
							1/4 inch galvanized steel ballast chain - 65 lbs / 100 ft.
							5/16 inch galvanized steel ballast chain - 100 lbs / 100 ft.
							1/4 inch 6 X 19 vinyl coated galvanized steel (aircraft cable) toplod cable 5880 lb breaking strength.
							5/16 inch 6 x 19 vinyl coated galvanized steel (aircraft cable) toplod cable 9160 lb breaking strength.
							Galvanized steel safety snap top connection

NOTES

1. The filter fabric in Type 3.DOT barriers cannot be heat sealed. It must be sewn.
2. Any special depth of barrier will be supplied to order. Call your Distributor for pricing.
3. Any special length of barrier will be supplied to order. Call your distributor for pricing.
4. Heavier weight fabrics will be supplied to order. Call your Distributor for pricing.
5. Buoyancy is increased on special depths. See the Selection Guide below.
6. The entire skirt of both Types 1.DOT and 2.DOT barriers can be fabricated using filter fabric in lieu of vinyl.

BARRIER SELECTION GUIDE							
Current	Curtain Depth in Feet						
(ft. per sec.)	0-5	5-10	10-15	15-20	20-25	25-30	30+
0	A	A	A	A/B	B/C/D	C/D	D
1	A	A/B	B	B	B/C/D	C/D	D
2	B	B	B	B/C	C/D	D/E	D/E
3	B	B	B	B/C	C/D	D/E	E
4	B	B	B/C	C/D	C/D	D/E	E
5	B	B/C	B/C	C/D	D	E	E

Note: All blue shaded areas on the chart exceed working cable loads unless specially designed.

- A. Type 1.DOT, 18 oz. fabric, 6 inch floatation, standard anchorage.
- B. Type 2.DOT, 18 oz. fabric, 8 inch floatation, special anchorage, engineering recommended.
- C. Type 2.DOT, 18 oz. fabric, 10 inch floatation, special anchorage, engineering recommended.
- D. Type 2.DOT, 22 oz. fabric, 10 inch floatation, special anchorage, engineering recommended.
- E. Type 2.DOT, 22 oz. fabric, 12 inch floatation, special anchorage, engineering recommended.